



# ACR Control Platforms

Multi-Axis and  
Single-Axis Controllers



ENGINEERING **YOUR** SUCCESS.

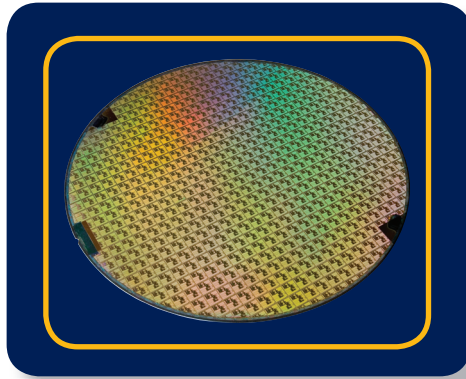

A global leader in motion control, Parker understands the challenges facing OEMs in such high-tech industries as medical device, semiconductor and flat panel display manufacturing. To help meet these challenges, Parker has built a team of highly experienced motion system designers who use a systematic project management process to deliver the most advanced linear motion technology available. And it's all backed by the global infrastructure high-tech OEMs look for in motion partners.

For medical device manufacturers, Parker's integrated automation solutions are specifically designed to reduce both your time to market and engineering costs while helping you comply with today's stringent government regulations.

With expertise in vacuum preparation, cleanroom preparation facilities, and extensive large-format system experience, we design and build motion components and systems that enable your technology and increase your throughput through precise and coordinated motion.

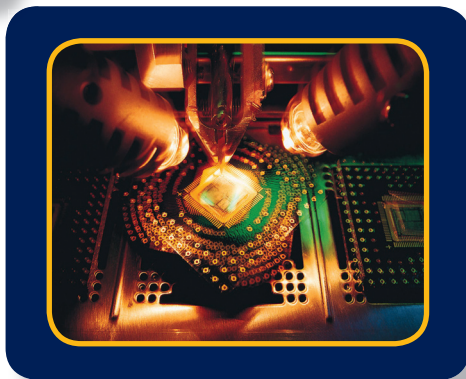
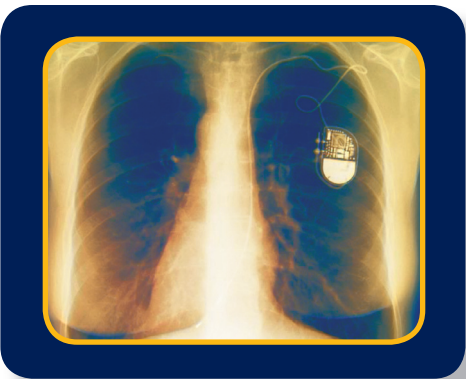



Industrial automation solutions from Parker Automation combine speed, accuracy and high-load capability to give machine builders and OEMs a competitive edge.

Parker is the only supplier that can provide complete technical and engineered solutions to OEMs for any packaging requirement. Parker's innovative engineering, breadth of line, worldwide distribution, and outstanding customer service set the standard for the industrial motion market.

- Application Analysis
- Engineering Assistance
- Systems Design
- Assemblies, Kits and Sub-Systems
- 2-Year Warranty
- ISO Certified
- Global Support and Services



# System Design Solutions

Parker's comprehensive motion control platforms allow machine designers to choose the motion control architecture that best fits their specific application. Multi-axis or single-axis, centralized or distributed, PC controlled or standalone, Parker has the solution.

## Common Software Environment

Whichever control platform is chosen, engineers can now configure, program and operate Parker controls within a single software environment, ACRView. The ACRView environment supports Parker's traditional analog multi-axis controls and drives, the multi-axis ETHERNET Powerlink motionbus system and the Aries Controller single axis drive/controller. This common software environment enables machine designers and end users to take advantage of the high-performance ACR servo control for both single-axis and multi-axis projects without switching between or relearning different control languages and software environments. Benefits of the common control language and software include reduced time to market and lower overall motion system costs.

## Scalability

Different machines have different motion requirements. With Parker's scaleable ACR Controls Platform, it doesn't matter whether your current design is large or small, point-to-point or coordinated, there's a Parker controller that's just right for the job. Save time and money purchasing only the control that's required. During the next project or design review, scaling up to multi-axis or down to a single-axis is as easy as the click of a button.

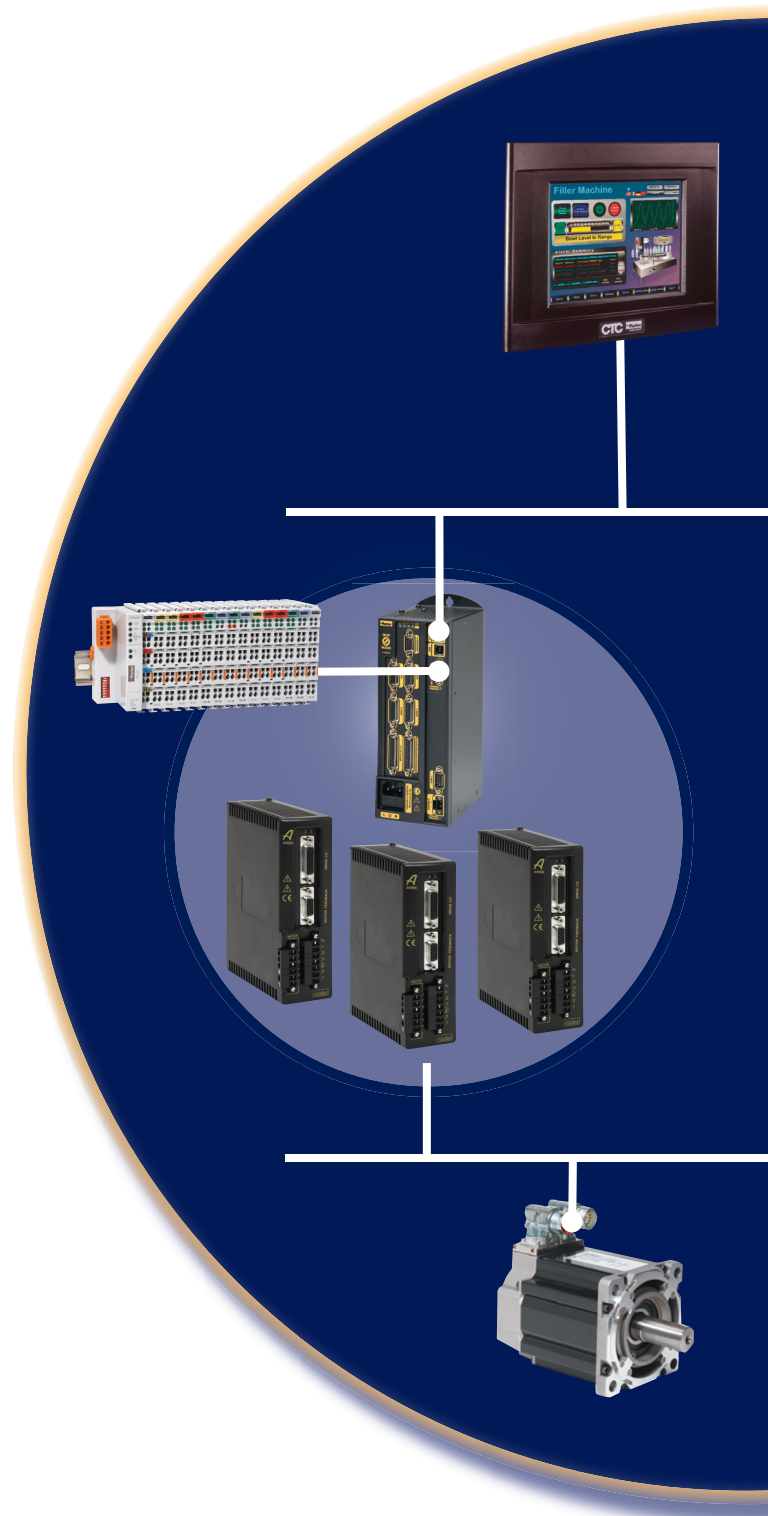



## Motion and Programming Capabilities

The ACR control platform supports a wide variety of motion control applications, providing the machine designer an unprecedented level of flexibility. Everything from single-axis point-to-point motion through multi-tasking programs controlling high-performance multi-axis circular interpolation is available within the ACR platform.

- Multitasking of up to 24 simultaneous programs
- Multiple coordinate systems
- Interpolation of up to eight axes in any combination
- On-the-fly motion parameter changes
- Segmented electronic camming
- Electronic gearing with real-time phase advance
- Linear, circular and helical interpolation
- Automatic tangential and parallel tool alignments
- Interruptible moves
- Analog or digital feedback
- Dual-loop feedback
- Gantry lock
- Data teach and playback
- Backlash and ballscrew compensation

## Connectivity

Support for Ethernet TCP/IP 10/100 Base-T, EtherNet/IP, USB2.0, RS232, RS485, and CANOpen ensures support for a wide variety of devices, including PCs, PLCs, expansion I/O and HMIs. Multiple channels are served simultaneously, giving users many options for PC and PLC connectivity.

### Parker ACR Control Solutions

- ACR9000 multi-axis controller
  - 1-8 axes, servo or stepper
- ACR ETHERNET Powerlink motion-bus controller
  - 1-16 axes, servo or stepper
  - (see pg. 23 for more details)
- Aries Controller
  - Single axis servo drive/controller

## Multi-Axis Motion Control

### ACR 9000 Motion Controller

#### Features

- Up to 8 axes of servo or stepper control
- Advanced multitasking of up to 24 simultaneous programs
- Interpolation of 8 axes in any combination
- 10/100 Base-T Ethernet
- USB 2.0
- EtherNet/IP compatibility
- Absolute Encoder support via SSI
- ACRView Software Development Kit
- 24 VDC optically isolated onboard inputs and outputs
- CANopen expansion I/O
- 120/240 VAC power input
- CE (EMC & LVD), UL and cUL Recognized

The ACR9000 is Parker's premier standalone motion controller, capable of controlling up to 8 axes of motion. The ACR9000 excels as a standalone machine and motion controller, interfacing with or working alongside a PLC. The ACR9000 includes easy-to-use project-development tools that enable fast, efficient application creation and maintenance. The ACR9000 is the solution for standalone applications requiring industry-leading performance in an affordable and easy-to-use package.

### Aries Digital Servo Drive

#### Features

- DriveTalk™ – ACR9000 controller can access all drive parameters
- Multiple feedback options - Smart encoder, Quadrature encoder, Heidenhain EnDat absolute encoder, and resolver feedback supported
- From 1 to 16A RMS continuous currents
- 120/240 VAC
- CE (EMC & LVD), UL Recognized

The Aries digital servo drives deliver all the performance benefits that digital drive technology has to offer, including fast update rates and ease of installation. The Aries can run rotary or linear servomotors with a wide range of feedback devices, making it the ideal drive choice to solve a variety of machine applications.

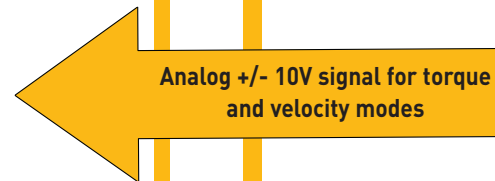

Analog +/- 10V signal for torque and velocity modes



DriveTalk™ makes Aries and ACR9000 a great match. Every axis on the ACR9000 includes a DriveTalk channel, which enables communication to Parker's Aries series servo drives. Configuration and diagnostics for the drive can be handled through the controller.



## Single-Axis Motion Control

### Aries Controller Single-Axis Servo Drive/Controller

#### Features

- 7 onboard inputs (4 standard, 3 high speed), 4 outputs
- Advanced Multitasking of up to 16 simultaneous programs
- Integrated 2 port Ethernet hub
- ACRView Software Development Kit
- Rotary or linear servo motor control
- 3, 4.5 and 6.3 A RMS continuous current
- 120/240 VAC power input
- Multiple feedback options –  
Smart encoder, quadrature encoder, Heidenhain EnDat absolute encoder
- Auto-tuning
- CE (EMC & LVD), UL Recognized

The Aries Controller single-axis servo drive delivers a wide range of standalone capabilities. The Aries Controller combines the performance benefits of the Aries digital servo drive with the industry-leading ACR9000 controller platform. With Ethernet connectivity, onboard I/O, and easy-to-use project development tools, commissioning single-axis motion is simple and efficient.

#### Powerful single-axis motion capabilities

Leveraging the industry-leading performance of the ACR9000 motion platform in a single-axis form factor, the Aries Controller contains motion and programming capabilities far beyond its peers. From multitasking programmability to encoder-based following with real-time phase advance, the Aries Controller is the highest-performance single-axis controller in its class.

- Multitasking of up to 16 simultaneous programs
- Position, velocity and torque control
- Incremental or absolute motion
- Trapezoidal or segmented move profiles
- On-the-fly motion parameter changes
- Linear and S-curve accelerations
- On-board programmable limit switches
- High-speed (1us) position capture registers
- Registration moves
- Indexing moves
- Electronic gearing with real-time phase advance

The Aries Controller combines the powerful features of the ACR Controller with the Aries digital servo drive for a complete stand-alone servo solution in one small package.

## ACR...Connect



The EtherNet/IP™ network is designed to use standard Ethernet and TCP/IP equipment for the industrial environment. The application layer protocol is an open standard—CIP™ (Control and Information Protocol). CIP is the same upper-layer protocol used by DeviceNet™ and ControlNet™ networks, allowing interoperability between various industrial devices.

### EtherNet/IP Included

The ACR can operate as a server/slave device within an EtherNet/IP network. This protocol is enabled in all ACR controllers with Ethernet. No special order code or software is required. The EtherNet/IP protocol can run alongside standard TCP/IP, bringing together plant floor automation and office networks.

### ACR with Interact and InteractX™

Integrating the ACR with Parker CTC's HMI is accomplished over EtherNet/IP.

- Drivers are available to enable communications to PA, EPX, PS, PX, HPC and HPX series
- Supports point-to-point or network connections
- Parameters and BIT address referencing
- InteractX Windows® HMI with unlimited tags
- Breakthrough graphic technology
- Panel tool library for easy screen development (no scripting)



## Advanced Motion with PLC Automation

EtherNet/IP capability gives ACR users a popular connectivity option to PLCs and other master devices supporting the protocol.

Applications can be developed in AcroBASIC and reside in the 9000. The controller is added to the EtherNet/IP network as a slave I/O device, allowing the master PLC to interrogate or set any controller parameter, variable value or to initiate a motion sequence. The master has continuous access to ACR parameters and flags. Simply assign an IP address to the ACR without any additional set-up to integrate into the network.

When advanced motion is required in a machine utilizing PLCs, the ACR is an easy-to-integrate alternative. Let the ACR be the “motion module” in the PLC system to handle complex motion requirements such as linear and circular interpolation, contouring, camming and gearing.

### Class 1 and Class 3 CIP Messages are Supported by the ACR

Class 1 (UDP) – I/O with Cyclic Updates Implicit messaging is a “Class 1” connection type, providing point-to-point or multicast messaging over a UDP connection. Typical applications use implicit messaging for I/O data transfer. Data is sent cyclically based on a user-defined duration. In most PLCs, the ACR will be seen as an Ethernet-based I/O block.

Class 3 (TCP) CIP Messages (connected and unconnected) Explicit messaging is a “Class 3” connection type, providing point-to-point, event-driven messaging over a TCP connection. The scanner/master PLC device reads and writes data to the slave. In a typical application, a function block in a ladder program would be used to send a message to the ACR to command or change motion.

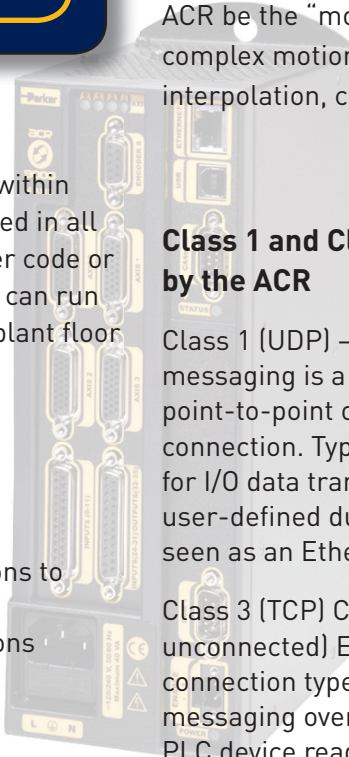





## ACR...Solutions

Connectivity and communication features give the ACR flexibility for use in a wide variety of machine architectures. The ACR excels as a standalone machine and motion controller, interfacing with a PC or working alongside a PLC.

### AcroBASIC

The ACR series of controllers utilizes a dedicated high-level programming language called AcroBASIC. This easy-to-use language supports a wide range of motion, I/O and communication functions. Several hundred intuitive mnemonic commands are incorporated into AcroBASIC for quick application development. The open nature of the ACR appeals to advanced programmers as well. Virtually every possible motion parameter and flag can be readily accessed, allowing the user to tailor applications to the specific machine requirements.

### MultiTasking

The ACR controllers are true pre-emptive multitaskers capable of performing multiple tasks simultaneously and toggling tasks based on the program conditions. The ACR multitasker can control up to 16 AcroBASIC programs simultaneously. The ACR9000 can also control an additional 8 ladder logic PLC programs. Due to the pre-emptive nature of the multitasking kernel, programs are only allocated processing time when running. Programs can be called on an as-needed basis.

### Motion Features

The ACR is loaded with powerful motion functionality, including:

- Segmented electronic CAM
- Electronic gearing with real-time phase advance
- Linear interpolation of up to 8 axes
- Programmable limit switch with multiple sources
- Advanced gantry control
- 3D arcs and tangent axis control
- Hardware & capture registers
- Time-based moves

### Fast Ethernet & USB 2.0

With the P1 or P3 options, the ACR9000 is equipped with both 10/100 BaseT Ethernet and USB2.0. The Aries Controller supports 10/100 BaseT Ethernet only.

### PC-Centric Applications

In many machines, a host PC is responsible for management of the user interface, motion control, I/O, vision and other processes. For the OEM and end-users that require custom PC software, Parker supplies libraries for developing applications in C++, VB and .NET. The ComACRsrvr, a 32-bit OLE automation (COM) server, is included with the ACRView Software Development Kit along with numerous sample applications. An extensive collection of functions is included to enable fast and stable communication, data sharing and motion.

With 100Mbps Ethernet, the ACR becomes a viable alternative to controller cards installed in the PC. Installation, wiring and maintenance are greatly simplified and free up the PC slots for other devices.

### Machine Control with the ACR9000

Onboard and expansion I/O and the multitasking programming environment make the ACR9000 a powerful choice for standalone machine control. The ACR9000 PLC programs incorporate a set of ladder-logic commands that can run alongside the motion programs for more flexible error handling and I/O monitoring. A full 200-line PLC program is scanned every 2ms and a total of 8 programs can be included in the scan cycle.

With the expansion I/O port, the ACR9000 becomes a CANopen master and is able to control devices that follow the DS401 protocol for I/O devices. The CANopen expansion I/O supports up to 4 nodes and over 1000 digital points.

Adding devices such as operator interfaces and vision can be accomplished over Ethernet.

## ACRView Software Development Kit

ACRView is a powerful project-development suite that assists the user of the ACR family products in programming, debugging and commissioning their application. Many features are incorporated to assist both the novice and expert users in developing code. All the tools needed to build and maintain a motion project are included:

- Ethernet, USB, CANopen and serial connection support
- Project Configuration Wizard
- Servo tuning tools
- Built-in oscilloscope, strip chart and XY plot
- Structured text program editor with color coded syntax checking
- Ladder logic program editor
- Real-time terminal interface
- Servo loop diagnostic tool
- Comprehensive status panels
- Integrated online help files

### Configuration Wizard

Project set-up is streamlined through the use of the Configuration Wizard. The ACR can be configured in a matter of minutes as the user is guided through a series of simple steps. ACRView will set the necessary parameters to have the controller ready for motion and code development.

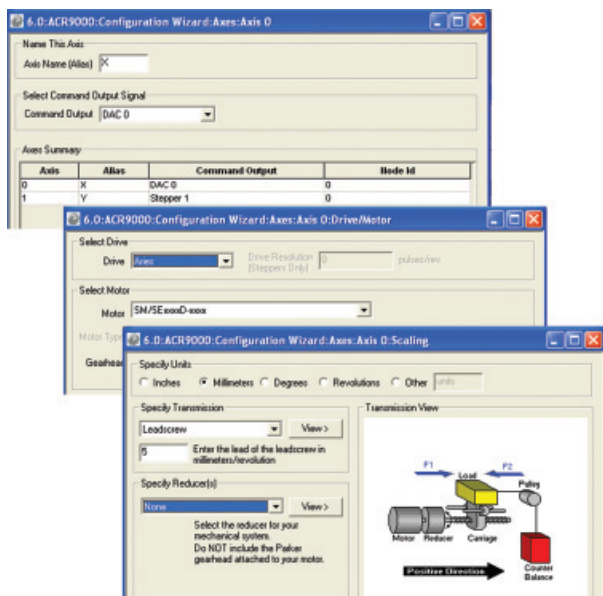

### Terminal, Help and Project Tree

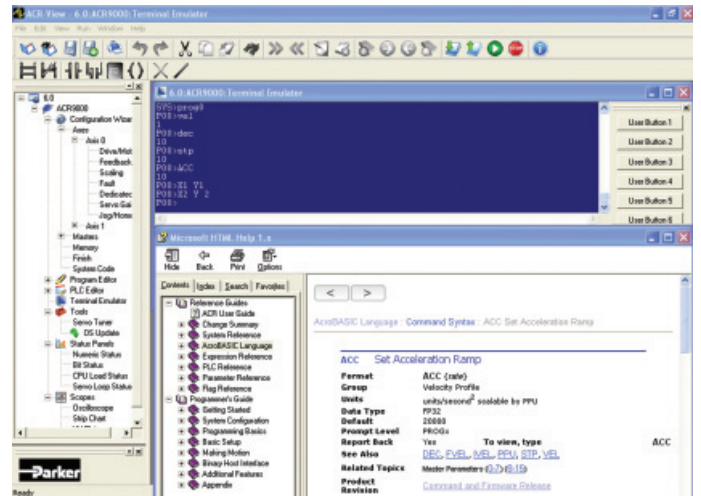

### Commissioning

Within the Configuration Wizard is an easy-to-use commissioning tool. Quickly verify the key motion and hardware settings for each axis, such as direction, velocity and limit function. Users can then proceed to programming with confidence in the physical settings.

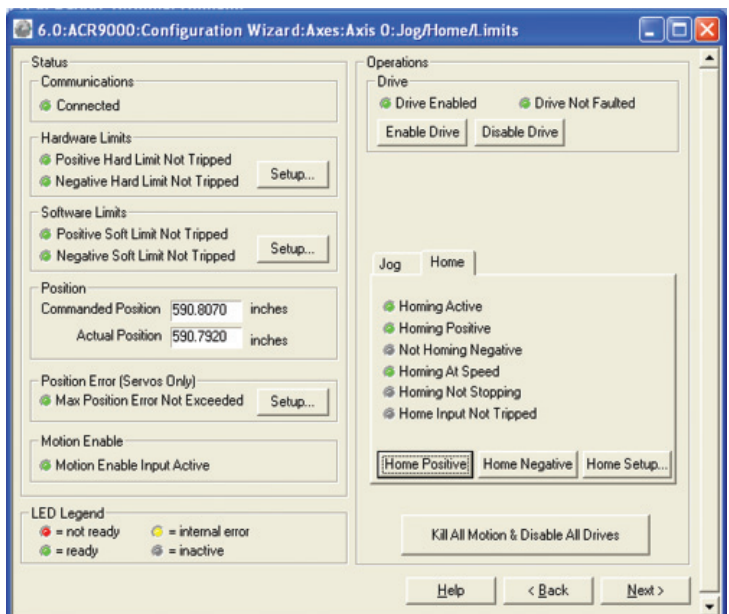



# ACRView Software Development Kit

## Editors

Program and ladder editor tools allow straightforward development of both motion and I/O application code. Color-coded syntax checker assists in programming. PLC programs can be written in either ladder or text.

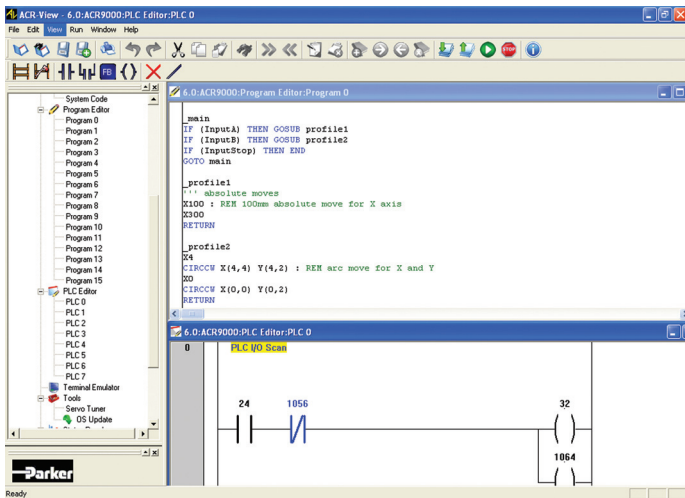

## Tuning

Servo tuning can be optimized with ACRView's powerful oscilloscope feature. Up to four channels of data can be observed and stored. Tuning gains are updated to best fit the needs of the application.

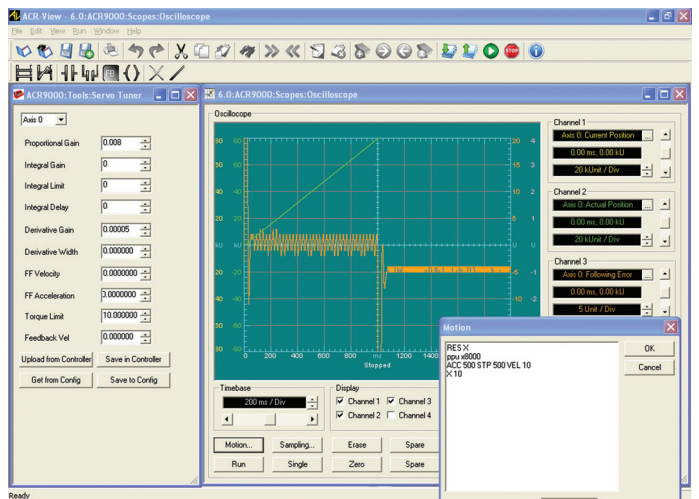

## XY Plot

In addition to the oscilloscope, ACRView includes an XY Plot, which allows the user to display X vs Y positions for two pairs of axes at once. Easily visualize 2-D path, using any of the onboard position parameters.

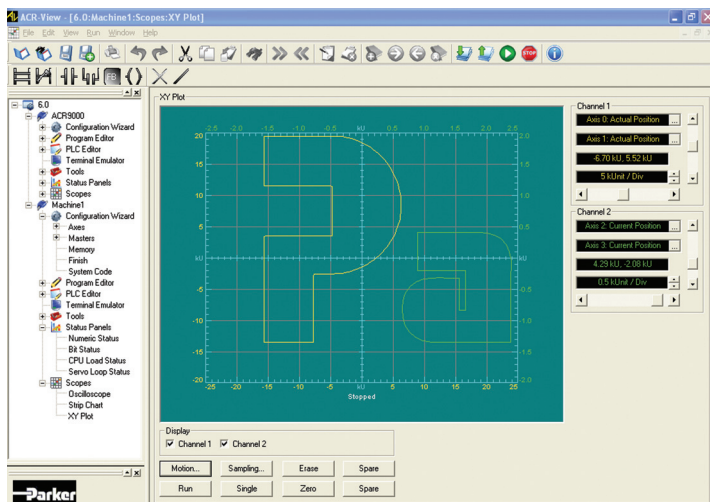

## Status Panels

View virtually any parameter or flag within the controller using the Bit and Numeric Status panels. The Servo Loop Status panel allows in-depth analysis of servo operation.

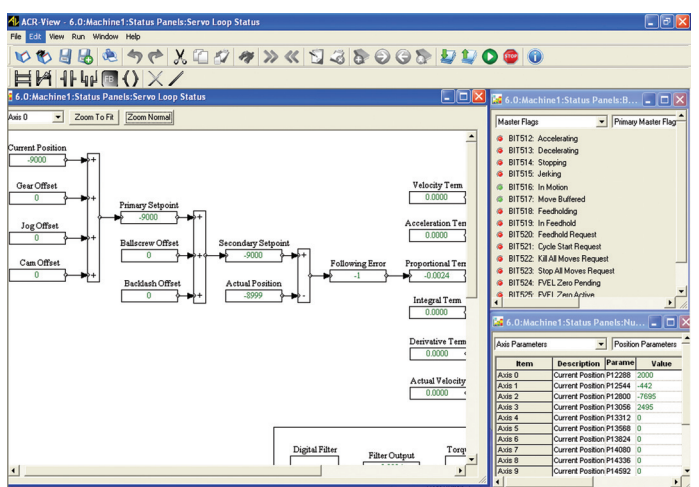

## ACR MotionCOMponents Tool Kit

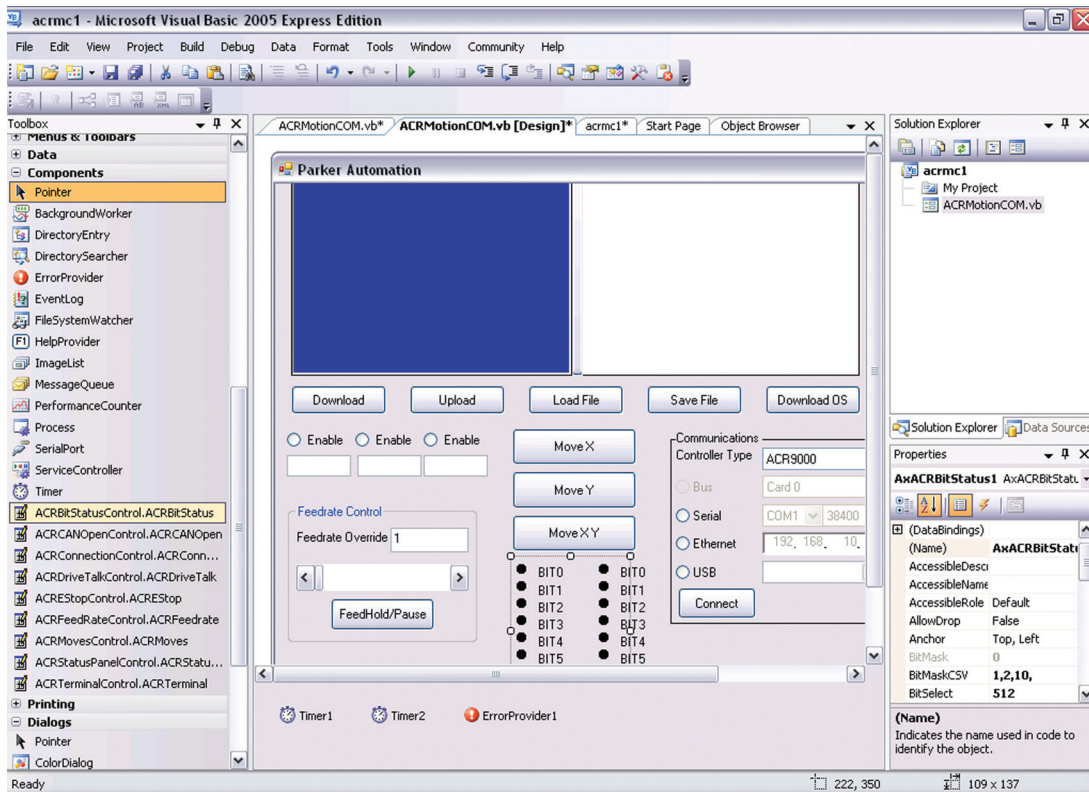

The ACR MotionCOMponents Tool Kit is an extensive collection of components and controls to allow a software developer to quickly and easily build a custom user interface for PC-based motion control applications. The tools incorporate a full set of ACR function calls, enabling complete control of any ACR family controller from a PC program.

### Includes:

- Connection Control for Ethernet, USB, serial or PCI communication with any ACR controller
- Terminal Control for direct command input and file transfer
- Monitor Control for viewing the status of motion critical flags and parameters
- Teach Control for jogging axes and saving data to arrays
- Playback Control for running profiles created with the Teach Control
- CANopen Control for seamless integration of a CANopen network
- Bit and Numeric Status Controls for convenient display of any controller flag or parameter

- Moves Control for multi-axis motion commands
- DriveTalk Control for communication with Aries drives from the ACR controller

### ACR Features:

- Available in both .NET and ActiveX versions
- 12 integrated tools containing more than 100 ACR function calls
- For use with all ACR series controllers
- Pre-built graphical controls for faster development
- Easy, hassle-free installation and set-up
- Functional User Interfaces can be developed in minutes
- Graphical objects include wrapper classes for greater convenience



# ACR MotionCOMponents Tool Kit

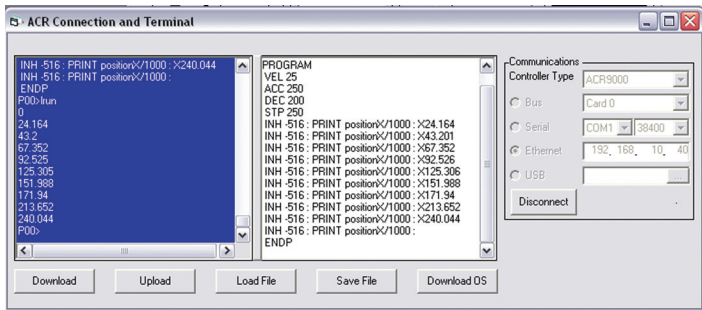

## Connect and Talk

The Connection Control establishes communication to any ACR controller and is the main link for all other controls in a project. The Terminal Control allows the user to input commands and queries for immediate execution. Utilities are included for program transfer.

## View and Monitor

The StatusPanel Control displays key motion parameters and flags in one convenient tool. Panels are also available to easily customize the polling of data from the controllers.

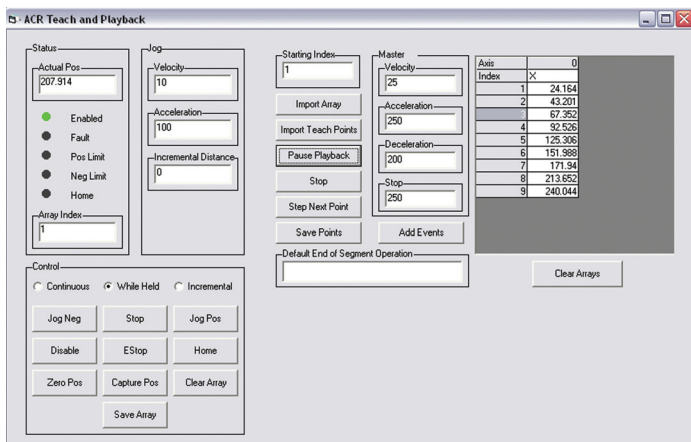
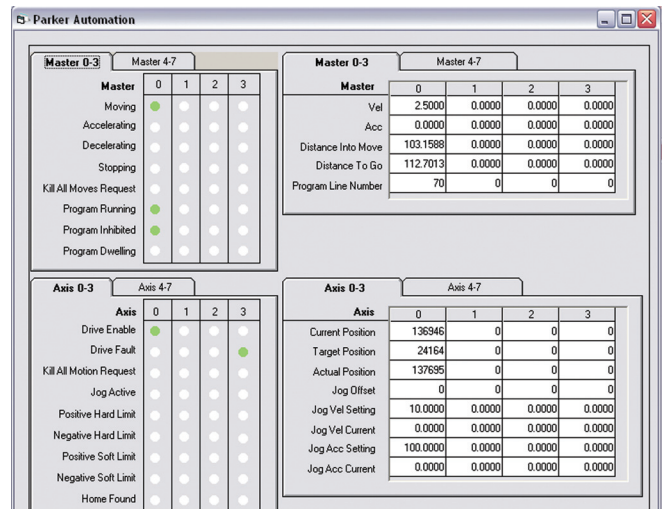

## Jog, Teach and Play

The TeachPanel control is ideal for controlling basic motion functions. Includes homing and drive control, along with position data. This control allows the user to jog to fixed positions and then capture the data in arrays for later playback. The Playback Control plays recorded positions for multi-axis coordinated motion.

**ACR MotionCOMponents Tool Kit is available for download, free of charge, at [www.parkermotion.com/support.htm](http://www.parkermotion.com/support.htm)**

## ACR9000 Specifications

### Hardware

Axes/controller	2, 4, 6 or 8 axes
Processor	32-bit floating-point DSP @ 150 MFLOPS / 75 MHz
Trajectory calculation	64-bit precision
User memory	1 MB Flash-based. Retains user programs and system configuration parameters
Firmware	Flash-based
Size	3.58" W x 10.5" H x 5.3" D (2-4 axes), 5.0" W x 10.5" H x 5.3" D (6-8 axes)
Operating system	Multi-tasking RTOS
Battery Backup	Non-volatile memory retains all system and user variables. (Optional)

### Performance

Multi-tasking	8 coordinate systems/16 text programs/8 ladder programs
Trajectory update	Every 100-500 $\mu$ s
Ladder Logic PLC	100-500 $\mu$ s scan time
Interpolation	Linear, circular, sinusoidal, helical, elliptical, spline, 3D arcs
Servo loop	PID, velocity feed forward, acceleration feed forward, Notch and LoPass filtering
Position capture	Hardware, < 1usec

### Communications

Serial Interface	1 serial port (RS232 and/or RS422)
Ethernet	10/100 Base-T
USB	2.0
CANopen	DS401 protocol for I/O devices. (Optional)

### Command Signal

Analog outputs	16-bit resolution DAC, up to 8 outputs
Stepper outputs	Up to 8 @ 2.5 MHz maximum

### Inputs/Outputs

Encoder input	Up to 10 at 20 MHz post-quadrature maximum Software configurable for Synchronous Serial Interface (SSI), quadrature, step and direction, CW/CCW modes
Onboard analog inputs	8 single-ended (4 differential) inputs @ 12-bit resolution (optional)
Digital Onboard I/O	20, 24 VDC optically isolated onboard inputs for 2 to 4 axes 40, 24 VDC optically isolated onboard inputs for 6 to 8 axes 4, 24 VDC optically isolated onboard outputs for 2 to 4 axes 8, 24 VDC optically isolated onboard outputs for 6 to 8 axes

### Software provided

Development Software	ACRView Software Development Kit
Language Support	Libraries for C++, VB6, C#, VB.NET



# ACR9000 Dimensions

## 2 to 4 axes

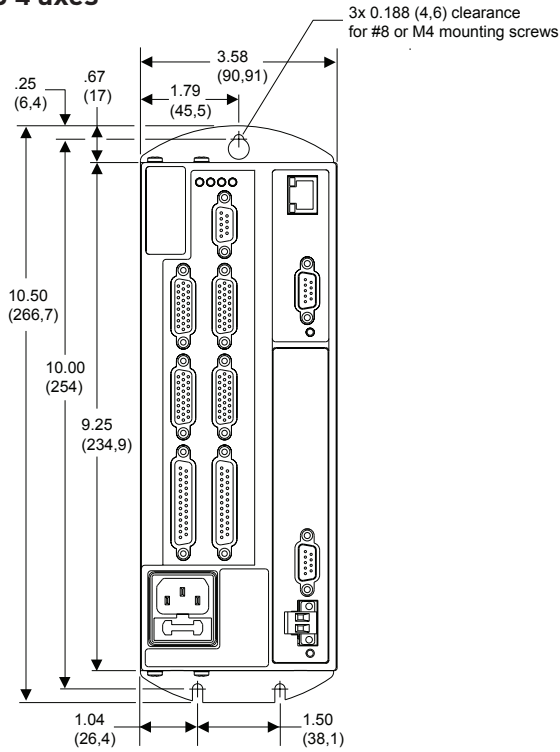

## 6 to 8 axes

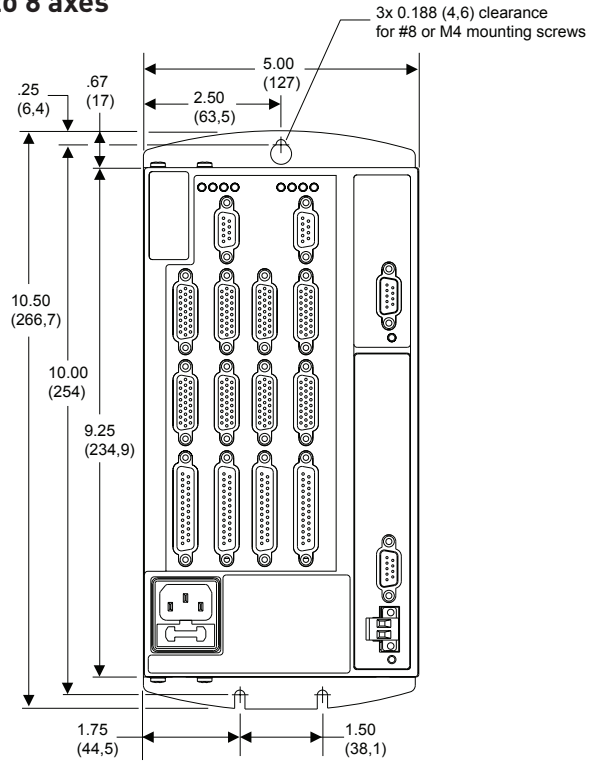

### ACR9000 Dimensions

Controller	Overall depth in (mm)
ACR9000 U2, U4, U6 & U8	5.30 (134,6)

# ACR9000 Part Numbering System

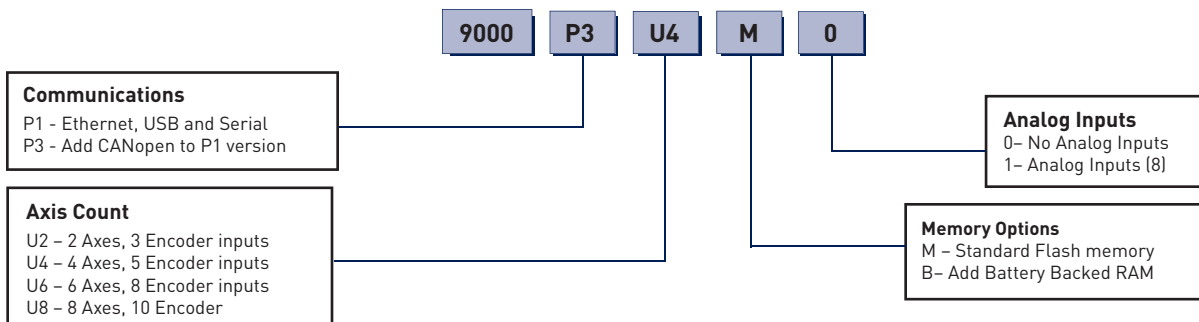

Example: **9000P3U4M0**  
4 axis controller with Ethernet, USB, Serial, CANopen and Standard Flash memory

## Aries Drive Specifications

	AR-01	AR-02	AR-04	AR-08
<b>Motor Output Power</b> Shaft Power @ Continuous Current Shaft Power @ Peak Current <b>Drive Output Power</b> Continuous Current (RMS) Peak Current (RMS) Bus Voltage PWM	100 Watts* 300 Watts* 1 Amp 3 Amps	200 Watts* 600 Watts* 1.75 Amps 5.25 Amps	400 Watts* 1200 Watts* 3 Amps 9 Amps	750 Watts* 2250 Watts* 4.5 Amps 13.5 Amps
<b>Drive Input Voltage</b>	170/340 VDC 16 or 32 kHz, motor dependent 120/240 VAC, 1Ø, 50/60 Hz			
	AR-13	AR-20	AR-30	
<b>Motor Output Power</b> Shaft Power @ Continuous Current Shaft Power @ Peak Current <b>Drive Output Power</b> Continuous Current (RMS) Peak Current (RMS) Bus Voltage PWM	1300 Watts* 3900 Watts* 6.3 Amp 14.2 Amps 170/340 VDC 16 or 32 kHz, motor dep.	2000 Watts* 6000 Watts* 10 Amps 30 Amps 340 VDC 16 kHz	3000 Watts* 9000 Watts* 16 Amps 48 Amps 340 VDC 16 kHz	120/240 VAC, 1Ø, 50/60 Hz
<b>Drive Input Voltage</b>	120/240 VAC, 1Ø, 50/60 Hz	240 VAC, 1 or 3 Ø, 50/60 Hz	240 VAC, 3 Ø, 50/60 Hz	
<b>Performance</b> Servo Update Accuracy Commutation <b>Inputs</b> Command Enable/Reset Encoder Resolver <b>Outputs</b> Fault Brake Encoder Out <b>Communications</b> Type Baud Rate Multi-drop Drive talk <b>Standards</b> <b>Environmental</b> Temperature Humidity	62.5 µ seconds ± 1 encoder count; encoder dependent Sinusoidal 14-bit resolution ADC, ± 10 V (torque/velocity control) Step and direction, 2 MHz max (position control) 5-24 VDC 5 MHz (pre-quadrature); RS-422 compatible differential input 12-bit A to D input (gives 4096 counts/rev), absolute accuracy 11 arc-min 5-24 VDC Solid state, normally open; 1 Amp @ 24 VDC max RS-422 compatible differential driver; 5 MHz max. output frequency (pre-quadrature) RS-232 (3-wire)/RS-485 (2-wire) ASCII Fixed at 9600 Up to 99 units (RS485 only) RS-485 (2 wire) UL Recognized 508c, CE (LVD), CE (EMC) 0-45° C (32-113° F) except AR-13_E 0-40° C (32-104° F) 0-95% non-condensing			
* @ 240 VAC				



# Aries Drive Dimensions

## AR-01 - AR-13

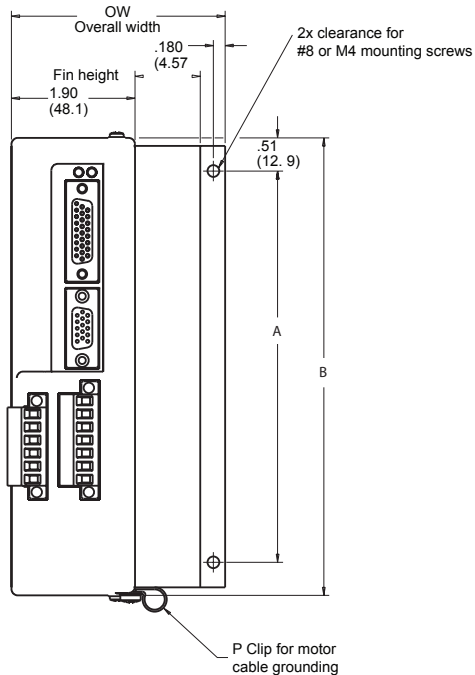

## AR-20 & AR-30

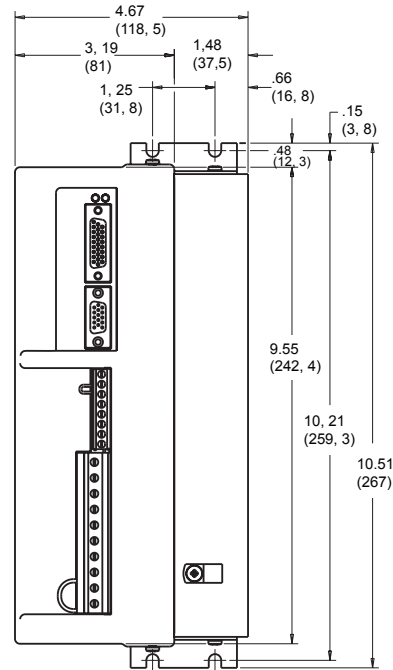

Aries Drive Dimensions						
Drive	A- in (mm)	B- in (mm)	Fin Height in (mm)	Overall Width (OW) in (mm)	Overall Depth in (mm)	Overall Depth with Cables in (mm)
AR-01	5.00 (127)	6.02 (153)	0.010 (0,25)	2.29 (58,2)	5.05 (128)	7.60 (193)
AR-02	5.00 (127)	6.02 (153)	0.375 (9,5)	2.65 (67,3)	5.05 (128)	7.60 (193)
AR-04	6.00 (152)	7.02 (178)	0.625 (15,9)	2.90 (73,7)	5.05 (128)	7.60 (193)
AR-08	6.00 (152)	7.02 (178)	1.000 (25,4)	3.28 (83,3)	5.05 (128)	7.60 (193)
AR-13	6.00 (152)	7.02 (178)	2.00 (50,8)	4.28 (108,7)	5.05 (128)	7.60 (193)
AR-20 & 30	-	-	1.48 (37,5)	4.67 (118,5)	6.72 (171)	9.27 (235,5)

# Aries Drive Part Numbering System

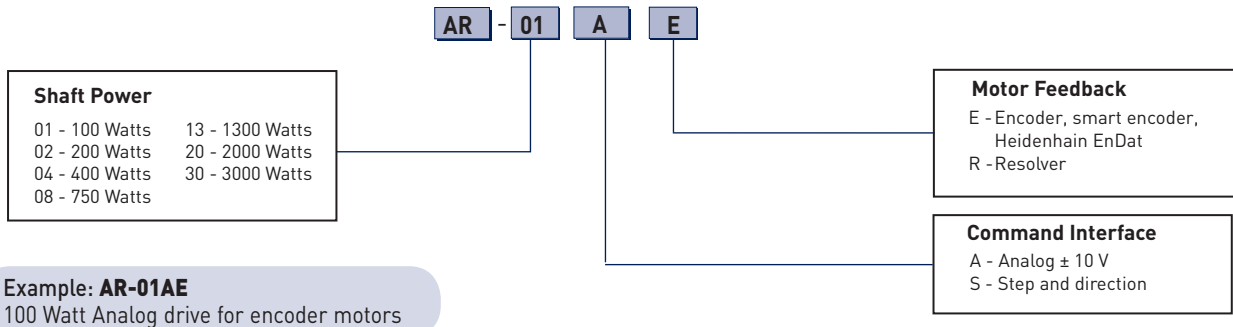

Aries Controller Specifications			
	AR-04	AR-08	AR-13
<b>Drive Output Power</b>			
Continuous Current (RMS)	3 Amps	4.5 Amps	6.3 Amps
Peak Current (RMS)	9 Amps	13.5 Amps	14.2 Amps
Bus Voltage		170/340 VDC	
PWM		16 or 32 kHz	
<b>Drive Input Voltage</b>	120/240 VAC, 1 phase, 50/60 Hz		
<b>Performance</b>			
Torque Loop Update		31.25 us	
Velocity Loop Update		125 us	
Position Loop Update		125 us	
Accuracy	+/-1 encoder count, encoder dependent		
Commutation	Sinusoidal		
<b>Environmental</b>			
Temperature	0-45C (32 - 113F)	0-45C (32 - 113F)	0-40C (32 - 104F)
Humidity		0-95%, non-condensing	
<b>Standards</b>	UL Recognized 508c, CE (LVD), CE (EMC)		
<b>Communications</b>			
Ethernet	10/100 Base-T, Dual RJ-45 connectors, Supports IP Protocols TCP/UDP		
<b>Inputs/Outputs</b>			
Digital Inputs	7 programmable inputs, 5-24 VDC (3 high-speed 1us capture, 4 standard)		
Digital Outputs	4 programmable outputs, 5-24VDC, 100mA max		
Brake Relay	solid state, NO, 1 amp @ 24VDC max		
Primary Encoder Input	1.6 MHz, differential, A, B, Z signals		
Secondary Encoder Input	1.6 MHz, differential, A, B signals		
<b>Feedback</b>	Incremental encoder, Parker SmartEncoder, EnDat absolute encoder		
<b>Memory</b>	512K non-volatile user memory		
<b>Support Software</b>			
Development Software	ACRView Software Development Kit		
Language Support	Libraries for C++, VB6, C#, VB.net, Motion COMponents ActiveX tools		



# Aries Controller Dimensions

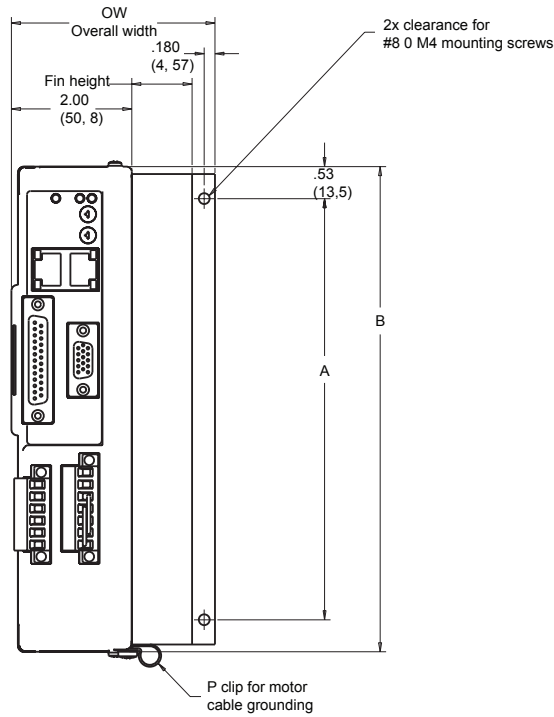

Aries Controller Dimensions						
Drive	A- in (mm)	B- in (mm)	Fin Height in (mm)	Overall Width (OW) in (mm)	Overall Depth in (mm)	Overall Depth with Cables in (mm)
AR-04	7.00 (177,8)	8.07 (204,9)	0.625 (15,9)	3.01 (76,3)	5.35 (135,9)	7.90 (200,7)
AR-08	7.00 (177,8)	8.07 (204,9)	1.000 (25,4)	3.38 (85,9)	5.35 (135,9)	7.90 (200,7)
AR-13	7.00 (177,8)	8.07 (204,9)	2.00 (50,8)	4.38 (101,3)	5.35 (135,9)	7.90 (200,7)

# Aries Controller Part Numbering System

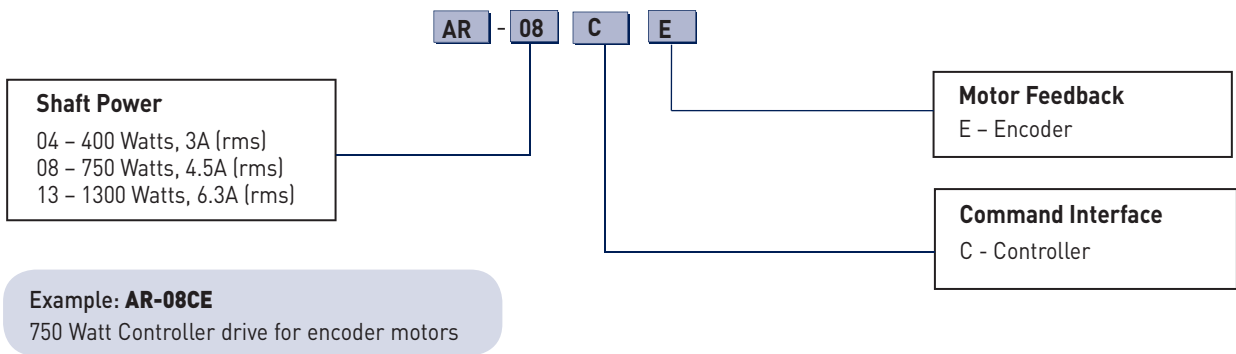

**ACR9000 Accessories**

**Part Number**

**Product Description**

**Drive Command Cables\***

71-021599-XX  
 71-021110-XX  
 71-021108-XX  
 71-023715-XX  
 71-021112-XX  
 71-022316-XX  
 71-021113-XX  
 71-022344-XX

ACR-to-Aries command cable (analog only)  
 ACR-to-ViX command cable  
 ACR-to-Compax3 command cable (analog only)  
 ACR-to-Dynaserv G3  
 ACR-to-Gemini command cable (analog only)  
 ACR-to-Gemini command cable (step & direction only)  
 ACR-to-stepper cable (25-pin stepper connector)  
 26-pin flying-lead cable

\*-XX

Cables offered in 4' (-04) or -10' (-10) lengths, e.g., 71-021599-04

**Expansion I/O Cable**

71-022338-02  
 71-022338-04

2' Expansion I/O cable (9-pin D-sub to flying lead)  
 4' Expansion I/O cable (9-pin D-sub to flying lead)

**Communication Cable**

71-016939-10

10' RS-232 communication cable

**Breakout Module**

VM25-PM

25-pin screw terminal breakout board for onboard I/O connector and Limit/Home connector (1 required for each connector) DIN rail mount (2' cable included)

VM26-PM

26-pin screw terminal breakout board for axes connectors, DIN-rail mount (2' cable included)

**AC Power Adapter**

43-011905-01

240 VAC Power plug adapter

**Power Supply**

PS-60W

24 VDC, 60 Watt power supply for I/O and enable

**Parker I/O System  
(Expansion I/O)**

PIO-337  
 PIO-347  
 PIO-430  
 PIO-402  
 PIO-400  
 PIO-530  
 PIO-504  
 PIO-501  
 PIO-468  
 PIO-480  
 PIO-550  
 PIO-552  
 PIO-600

PIO Bus coupler, CANopen standard  
 PIO Bus coupler, CANopen economy  
 PIO 24 VDC digital input module, 8 channel  
 PIO 24 VDC digital input module, 4 channel  
 PIO 24 VDC digital input module, 2 channel  
 PIO 24 VDC digital output module, 8 channel, 0.5 Amp  
 PIO 24 VDC digital output module, 4 channel, 0.5 Amp  
 PIO 24 VDC digital output module, 2 channel, 0.5 Amp  
 PIO 0-10 VDC analog input module, 4 channel  
 PIO 0-20 mA analog input module, 2 channel, differential isolated  
 PIO 0-10 VDC analog output module, 2 channel  
 PIO 0-20 mA analog output module, 2 channel  
 PIO end module



## Aries Drive Accessories

Part Number	Product Description
71-021609-01	Aries RS-232/RS485 communication dongle
71-021599-04	Aries to ACR analog command cable, 4 ft
71-021599-10	Aries to ACR analog command cable, 10 ft
71-021600-04	26-pin drive I/O to flying lead cable, 4 ft
71-021600-10	26-pin drive I/O to flying lead cable, 10 ft
VM26-PM	26-pin breakout for drive I/O with 2 ft cable
VM15-PM	15-pin breakout for feedback connector with 2 ft cable

## Aries Controller Accessories

Part Number	Product Description
VM25	25-pin breakout for user I/O with 2 ft cable
VM15-PM	15-pin breakout for feedback connector with 2 ft cable

## ACR...Partners

### Rotary and Linear Motors

Parker offers a complete line of motor products meeting a broad range of application needs. Parker Trilogy's linear motors offer industry-leading solutions for both ironcore and ironless technologies. The wide range of rotary servo motors includes the high-torque MPP Series, the smooth/high-inertia SM Series and the cost-effective BE Series.

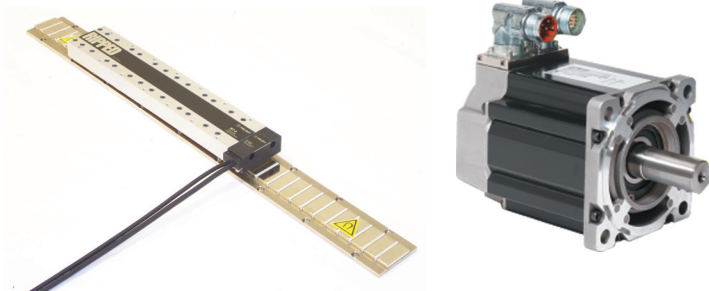

### Daedal and Bayside Mechanics

Parker offers the widest range of precision mechanical actuators in the industry. The 400XR series of modular linear positioners is available in an unrivaled array of sizes, features and options. Single- and multi-axis systems combine with the unique ACR features for performance and value.



**Ballscrew Compensation:** Use the error map data provided with a precision grade XR table to improve accuracy with the powerful yet easy-to-use ACR compensation feature.

**Gantry Control:** LOCK feature of ACR offers outstanding control of linear motor gantry systems. A dedicated feedback loop monitors and corrects the position of the parallel axes to maintain precise alignment.

### PIO

The modular Parker I/O System (PIO) is a convenient and flexible product for connecting field devices to an ACR. The PIO communicates with the controller via CANopen. A wide variety of digital and analog modules are available.

#### Features

- Opto-Isolated
- Compact, DIN-rail mount
- Easy to install and expand
- Safe, reliable contacting
- Different voltages can be combined
- Error and status LEDs

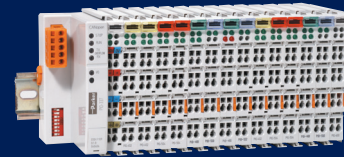

### CTC HMI - Human Machine Interface

Parker's range of HMI solutions include cost-effective, dedicated HMI panels as well as flexible industrial PCs running Windows®-based InteractX HMI software. Connectivity to the ACR is supported via EtherNet/IP. Application development is simplified by programming in a familiar environment, including support for OPC, ActiveX and Visual Basic.





# ETHERNET Powerlink Motion Bus Solution



## ETHERNET Powerlink Benefits

- Simplified Cabling
- Reduced installation times
- All-Digital system
- Single communication access point
- Standard cabling and hubs
- Scalable
- Modular design possibilities
- Centralized performance with distributed architecture

ETHERNET Powerlink (EPL) is a high-speed, digital motionbus solution connecting a motion controller to multiple drives and I/O points using standard Ethernet networking hardware. This centralized, real-time communication system for automation and motion control makes Ethernet deterministic for real-time industrial applications.

ETHERNET Powerlink is a powerful motionbus solution that combines the benefits of fieldbus network wiring, Ethernet speeds and visibility, consumer volume hardware costs and open platforms.

Parker's ETHERNET Powerlink solution includes the ACR90x0 multi-axis controllers, and the Aries EPL and Compax3 EPL servo drives. For more information on these ETHERNET Powerlink enabled products, visit [www.parkermotion.com/powerlink](http://www.parkermotion.com/powerlink).

ETHERNET   
**POWERLINK**  
Standardization Group

For more information, visit  
[www.parkermotion.com/powerlink](http://www.parkermotion.com/powerlink)



Parker Hannifin Corporation  
Electromechanical Automation Division  
5500 Business Park Drive  
Rohnert Park, CA 94928  
[parkermotion.com](http://parkermotion.com)