

**Attention:** To prevent electrical shock, disconnect from power source before installing or servicing. Keep free from contaminants.

**Achtung:** Vor Installations- oder Servicearbeiten Stromversorgung unterbrechen, um Unfälle zu vermeiden. Die Geräte müssen gegen Verschmutzung geschützt werden.

**Attenzione:** Per prevenire infortuni, togliere tensione prima dell'installazione o manutenzione. Tenere lontano da contaminanti.

**Attention:** Avant le montage et la mise en service, couper l'alimentation secteur afin d'éviter tout accident. Protéger le produit contre les environnements agressifs.

**Attenzione:** Desconectar la alimentación eléctrica antes de realizar el montaje y la puesta en servicio, con el objeto de evitar accidentes. Proteger el producto de los ambientes agresivos.



**Allen-Bradley**

**105-C09...43**

**107-C09...43**

**170-C09...43**

**173-C09...43**



IEC 60947; EN 60947;  
UL 508; CSA 22.2.Part 14

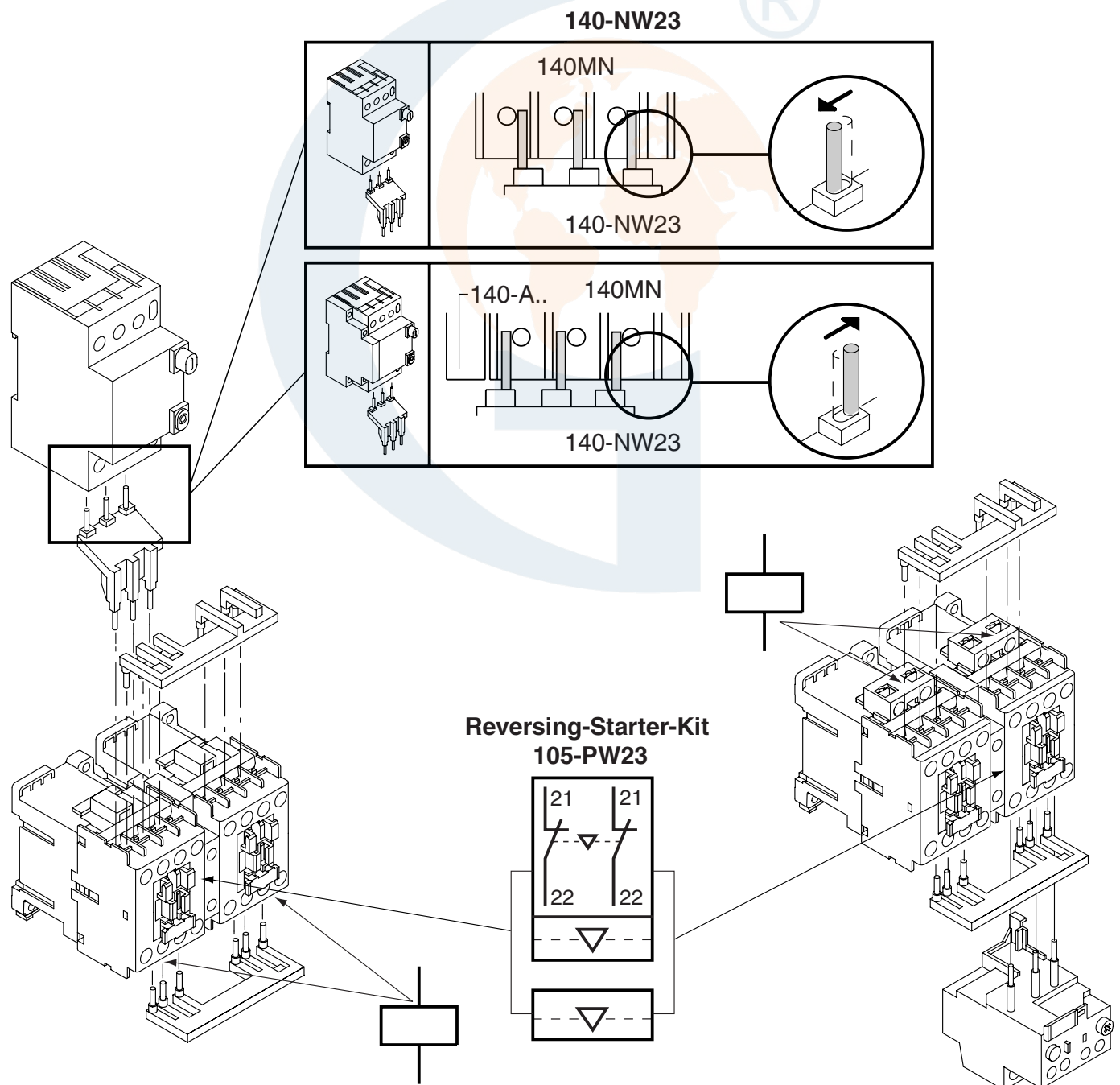



## Reversing-Starter-Kit 105-PW37 / 105-PW43

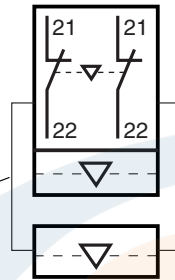
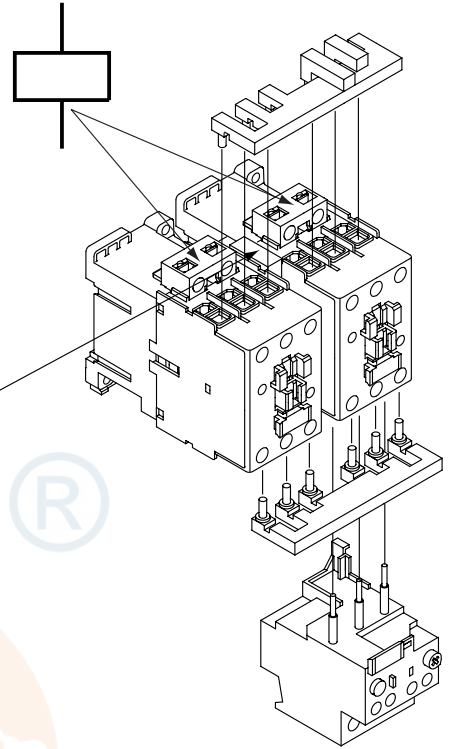
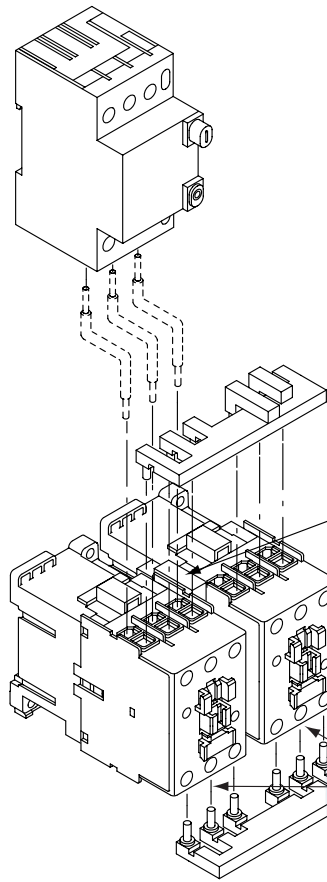

## Star-Delta-Wiring-Kit 170-PW23

## Star-Delta-Wiring-Kit 170-PW37

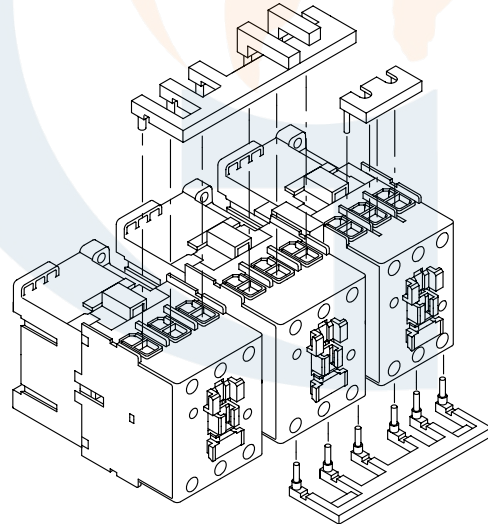
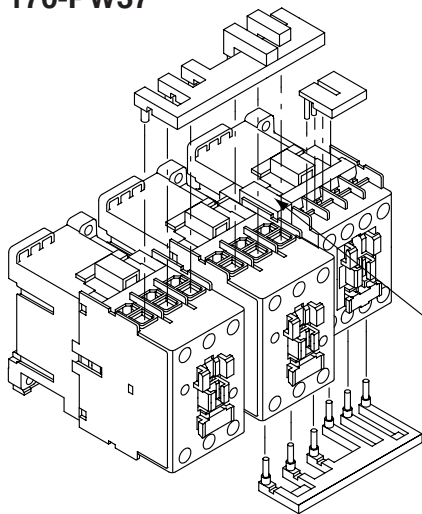

## Star-Delta-Wiring-Kit 170-PW43

